



Contents lists available at ScienceDirect

## Applied Mathematics and Computation

journal homepage: [www.elsevier.com/locate/amc](http://www.elsevier.com/locate/amc)

## The next step of the word problem over monoids

E. Güzel Karpuz<sup>a,\*</sup>, Fırat Ateş<sup>b</sup>, A. Sinan Çevik<sup>c</sup>, İ. Naci Cangül<sup>d</sup>, A. Dilek Maden (Güngör)<sup>c</sup><sup>a</sup> Department of Mathematics, Kamil Özdağ Science Faculty, Karamanoğlu Mehmetbey University, Yunus Emre Campus, 70200 Karaman, Turkey<sup>b</sup> Department of Mathematics, Faculty of Arts and Science, Balıkesir University, Çağış Campus, 10145 Balıkesir, Turkey<sup>c</sup> Department of Mathematics, Faculty of Science, Selçuk University, Alaaddin Keykubat Campus, 42075 Konya, Turkey<sup>d</sup> Department of Mathematics, Faculty of Arts and Science, Uludağ University, Görükle Campus, 16059 Bursa, Turkey

## ARTICLE INFO

Dedicated to Professor H. M. Srivastava on the Occasion of his Seventieth Birth Anniversary

**Keywords:**  
Monoid pictures  
Word problem  
Presentation  
Identity problem

## ABSTRACT

It is known that a group presentation  $\mathcal{P}$  can be regarded as a 2-complex with a single 0-cell. Thus we can consider a 3-complex with a single 0-cell which is known as a 3-presentation. Similarly, we can also consider 3-presentations for monoids. In this paper, by using *spherical monoid pictures*, we show that there exists a finite 3-monoid-presentation which has unsolvable “*generalized identity problem*” that can be thought as the next step (or one-dimension higher) of the word problem for monoids. We note that the method used in this paper has chemical and physical applications.

© 2011 Elsevier Inc. All rights reserved.

## 1. Introduction

Presentations of algebras through finite rewriting systems have received much attention since they admit simple algorithms for solving the word problem. Especially, when the considered algebras are monoids or groups, the notion of rewriting systems coincides with string-rewriting systems. We may refer to [2,4,10] for the relationship between homological finiteness condition  $FP_\infty$  and word problems. In this paper, we approximate to the word problem by using monoid pictures. This approximation will be called as *the generalized identity problem for monoids* which is the analogue of the next step (or one dimension higher) of the word problem.

Let  $M$  be a monoid defined by a presentation

$$\mathcal{P} = [\mathbf{y}; \mathbf{s}], \quad (1)$$

where  $\mathbf{y}$  is the set of *generating symbols* and, for distinct positive words  $S_+$  and  $S_-$  on  $\mathbf{y}$ , each  $S$  in the *relation set*  $\mathbf{s}$  is an ordered pair  $(S_+, S_-)$ . We remark that one of  $S_+$  or  $S_-$  could be the empty positive word. We usually write  $S: S_+ = S_-$ . Moreover,  $\mathcal{P}$  is said to be finite if  $\mathbf{y}$  and  $\mathbf{s}$  are both finite. One can define a monoid  $M(\mathcal{P})$  associated with  $\mathcal{P}$ . In fact  $M(\mathcal{P})$  is the quotient of  $\hat{F}(\mathbf{y})$  by the smallest congruence generated by  $\mathbf{s}$ , where  $\hat{F}(\mathbf{y})$  is the free monoid on  $\mathbf{y}$ . If  $W$  is a word on  $\mathbf{y}$ , then the congruence class  $\bar{W}$  denotes an element of  $M(\mathcal{P})$ . (The notation  $M$  will be used instead of  $M(\mathcal{P})$  at the rest of this paper.) A 3-monoid-presentation  $\mathcal{K}$  is a triple

$$[\mathbf{y}; \mathbf{s}; \mathbf{Y}],$$

where  $\mathbf{Y}$  is the set of *spherical monoid pictures* (see [3,9]) over the underlying presentation  $\mathcal{P}$ . Further,  $\mathcal{K}$  is said to be finite if  $\mathbf{y}$ ,  $\mathbf{s}$  and  $\mathbf{Y}$  are all finite. (At this point, we note that 3-monoid-presentation  $\mathcal{K}$  can be regarded as a connected 3-complex in homotopy theory which will not be needed here.)

\* Corresponding author.

E-mail addresses: [eylem.guzel@kmu.edu.tr](mailto:eylem.guzel@kmu.edu.tr) (E.G. Karpuz), [firat@balikesir.edu.tr](mailto:firat@balikesir.edu.tr) (F. Ateş), [sinan.cevik@selcuk.edu.tr](mailto:sinan.cevik@selcuk.edu.tr) (A.S. Çevik), [cangul@uludag.edu.tr](mailto:cangul@uludag.edu.tr) (İ. Naci Cangül), [agungor@selcuk.edu.tr](mailto:agungor@selcuk.edu.tr) (A.D. Maden (Güngör)).

We recall that the word problem for monoids is the same question with the question of asking for the existence of an algorithm to determine whether or not  $W_1 = W_2$  in  $M$  for arbitrary words  $W_1$  and  $W_2$  on  $\mathbf{y}$ . Let  $H$  be a finitely generated submonoid of  $M$ . Then, for any arbitrary word  $W$  on  $\mathbf{y}$ , the *submonoid word problem* for  $H$  in  $M$  is the problem of deciding whether or not  $W$  defines an element of  $H$ . It is clear that if  $H$  is trivial, then the submonoid word problem simply becomes the word problem. For the group case, Novikov ([8]) proved that *there exists a finitely presented group with unsolvable word problem*. As a natural extension of this result, we can think that there exists a finitely presented monoid with unsolvable word problem and then we can formulate the word problem for monoids as follows:

Let us consider a finite 3-monoid-presentation  $\mathcal{K}$ . For any arbitrary element of the *trivializer set*  $\mathcal{D}(\mathcal{P})$  ([3,9]), one can ask whether the image of this element is trivial or not under the induced homomorphism  $\theta_* : \mathcal{D}(\mathcal{P}) \rightarrow \mathcal{D}(\mathcal{K})$ .

After that, we can formulate the generalized identity problem for monoids as follows:

For any spherical monoid picture  $\mathbb{P}$  over the presentation  $\mathcal{P}$ , as in (1), is there an algorithm to decide whether  $\mathbb{P}$  is equivalent (relative to  $\mathbf{Y}$ ) to the empty picture, for a given finite 3-monoid-presentation  $\mathcal{K} = [\mathbf{y}; \mathbf{s}; \mathbf{Y}]$ ?

We note that, by the same approach, the generalized identity problem for groups has first been formulated by Bogley and Pride in [1, Theorem 1.6].

The main result of this paper is the following.

**Theorem 1.1.** *There is a finite 3-monoid-presentation  $\mathcal{K}$  with unsolvable generalized identity problem. Furthermore, since  $\mathcal{K}$  can be chosen, the word problem for the underlying presentation  $\mathcal{P}$  is solvable.*

Before giving the proof of Theorem 1.1, we may refer to [3,4,9,10] for the notions of pictures over monoid presentations, trivializer (i.e. generating pictures) and free resolutions which will be needed in the next section.

As explained in [9], the fundamental point of monoid pictures are actually (directed) Squier graphs. Therefore some graph invariants such as *graph index*, *graph energy* ([5,7]) can also be studied for these algebraic graphs and so for monoid pictures. We recall that since the indexes obtained from special type of graphs are proposed molecular structure-descriptors used in the modelling of certain features of the 3D structure of organic molecules, in particular the degree of folding of proteins and other long-chain biopolymers, they have a quite important role in chemistry. In other words, all well known applications of graph invariants in chemistry (see [6] for a brief summary) similarly hold for Squier graphs in a different manner.

## 2. Proof of the main theorem

In this section, we pick a special monoid  $M$  to obtain a finite 3-monoid-presentation  $\mathcal{K}$ . Then, by taking an arbitrary word  $W$  on the generating set of  $M$ , we will consider the set of spherical monoid pictures, say  $\mathbb{P}_W$ , such that each  $\mathbb{P}_W$  is defined over the presentation of  $M$ . Later, we will show that  $\mathbb{P}_W$  is equivalent to the empty picture if and only if  $W$  defines an element of a special submonoid of  $M$ , say  $L$ . Thus we can conclude that  $\mathcal{K}$  has unsolvable generalized identity problem since, by the assumption on  $L$ , the submonoid word problem for  $L$  in  $M$  is unsolvable.

Let us suppose that  $M$  is a finitely presented monoid with the presentation  $\mathcal{P}_M = [\mathbf{y}; \mathbf{s}]$  such that,

- (1) the word problem for the monoid  $M$  is solvable,
- (2)  $\mathcal{D}(\mathcal{P}_M)$  has a finite trivializer (see [9]),
- (3) there exists a finitely generated submonoid  $L$  of  $M$  such that the submonoid word problem for  $L$  in  $M$  is unsolvable.

In order to give an example of the above construction, we may take  $M$  to be the free abelian monoid  $F_2 \times F_2$  of two free monoids of rank 2 with the presentation

$$\begin{aligned} \mathcal{P}_M &= [x_1, x_2, X_1, X_2, y_1, y_2, Y_1, Y_2; x_1 X_1 = X_1 x_1 = x_2 X_2 = X_2 x_2 = 1, \\ & y_1 Y_1 = Y_1 y_1 = y_2 Y_2 = Y_2 y_2 = 1, \\ & x_i y_j = y_j x_i, \text{ (for all } i \text{ and } j)]. \end{aligned}$$

It is clear that  $M$  satisfies the conditions (1), (2) and (3).

Let  $M_{2,1}$  be a cyclic monoid of order 2 with the presentation  $\mathcal{P}_{2,1} = [x; x^2 = x]$ . Moreover let us consider the monoid  $T = M \times M_{2,1}$  given by a presentation (see [3])

$$\mathcal{P}_T = [\mathbf{y}, x; \mathbf{s}, x^2 = x, yx = xy (y \in \mathbf{y})]. \quad (2)$$

It is well known that  $M_{2,1}$  has a solvable word problem and also, by the assumption,  $M$  has a solvable word problem. Moreover, since both  $M$  and  $M_{2,1}$  are finitely generated,  $T$  is finitely generated and also the solvability of the word problem for  $T$  is obvious.

Before we proceed, we need the following definition.

**Definition 2.1.** Let  $y_1 \cdots y_j y_{j+1} \cdots y_n$  be a word on  $\mathbf{y}$ . Then a commutator monoid picture  $\mathbb{D}_{y_1 \cdots y_j y_{j+1} \cdots y_n}$  is a picture over  $[\mathbf{y}, x; yx = xy (y \in \mathbf{y})]$  of the form as depicted in Fig. 1(a). Moreover, if  $\mathbb{D}_{y_1 \cdots y_j y_{j+1} \cdots y_n}$  is a picture over  $[\mathbf{y}, x; x^2 = x, yx = xy (y \in \mathbf{y})]$ , then it is equivalent to a picture as shown in Fig. 1(b).

Suppose that  $\mathbf{w} = \{w_1, w_2, \dots, w_k\}$  is a set of words on  $\mathbf{y}$  which represents a finite set of generators of  $L$ . Let  $\mathbf{Y}_1$  be a finite set of spherical monoid pictures which generates  $\mathcal{D}(\mathcal{P}_M)$ . For each  $S: S_+ = S_- \in \mathbf{s}$ , let  $\mathbf{Y}_2$  be a finite set of spherical monoid pictures (see [3, Figs. 3(a) and (b)]) over the presentation  $\mathcal{P}_T$ , as given in (2). Also let  $\mathbf{Y}_3$  consists of the single picture  $\mathbb{P}_{2,1}^1$ , as drawn in Fig. 1(c). In fact, by [3, Lemma 4.4],  $\mathbf{Y}_3$  is the trivializer of  $\mathcal{D}(\mathcal{P}_{2,1})$ . Finally, for each  $w_i \in \mathbf{w}$ , let  $\mathbf{Y}_4$  be a finite set of monoid pictures over  $\mathcal{P}_T$  of the form as shown in Fig. 2(a). We note that the subpicture  $\mathbb{D}_{w_i}$  is a commutator monoid picture and fixed over the presentation  $[\mathbf{y}, x; yx = xy (y \in \mathbf{y})]$ .

Let  $\mathbf{Y} = \mathbf{Y}_1 \cup \mathbf{Y}_2 \cup \mathbf{Y}_3 \cup \mathbf{Y}_4$ . Since each  $\mathbf{Y}_j$  ( $1 \leq j \leq 4$ ) is finite,  $\mathbf{Y}$  is finite. Therefore we have a finite 3-monoid-presentation

$$\mathcal{K} = [\mathbf{y}, x; \mathbf{s}, x^2 = x, yx = xy (y \in \mathbf{y}); \mathbf{Y}],$$

such that the underlying presentation  $\mathcal{P}_T$  has solvable word problem.

For any word  $W$  on  $\mathbf{y}$ , let  $\mathbb{P}_W$  be a monoid picture of the form as shown in Fig. 2(b). As in  $\mathbb{D}_{w_i}$ , the commutator monoid subpicture  $\mathbb{D}_W$  is fixed over the presentation  $[\mathbf{y}, x; yx = xy (y \in \mathbf{y})]$ .

Now, we will show that  $\mathbb{P}_W$  is equivalent to the empty picture (relative to  $\mathbf{Y}$ ) if and only if  $W$  defines an element of  $L$ , and hence  $\mathcal{K}$  has unsolvable generalized identity problem since the submonoid word problem for  $L$  in  $M$  is unsolvable.

**Lemma 2.2.** *If  $W$  defines an element of  $L$ , then  $\mathbb{P}_W$  is equivalent to the empty picture (relative to  $\mathbf{Y}$ ) over  $\mathcal{P}_T$ .*

**Proof.** Suppose that  $W$  defines an element of  $L$ . Then, for some  $w_i$ 's from the set  $\mathbf{w}$ , the congruence class  $\overline{W} = \overline{w_1 w_2 \cdots w_n}$  will be an element in  $M$ . Thus there is a monoid picture  $\mathbb{B}$  over  $\mathcal{P}_M = [\mathbf{y}; \mathbf{s}]$  with the boundary label  $w_1 w_2 \cdots w_n = W$ . Now let us consider the monoid picture  $\mathbb{P}'$  as in Fig. 3(a), where  $\mathbb{D}_{w_1 w_2 \cdots w_n = W}$  is a commutator monoid picture. We note that  $\mathbb{P}'$  is equivalent to the picture  $\mathbb{P}''$  as depicted in Fig. 3(b). By [3, Section 4.1], the set  $\mathbf{Y}_1 \cup \mathbf{Y}_2$  is a trivializer of  $\mathcal{D}([\mathbf{y}, x; \mathbf{s}, yx = xy (y \in \mathbf{y})])$ . Thus the picture  $\mathbb{P}''$  (and so  $\mathbb{P}'$ ) is equivalent (relative to  $\mathbf{Y}_1 \cup \mathbf{Y}_2$ ) to the empty picture.

If we insert  $\mathbb{P}'$  at the top of  $open\mathbb{P}_W$  and apply the collection of the operations defined in [3,9], then we obtain the monoid picture  $\mathbb{P}_W^1$ , as in Fig. 2(c), which contains two subpictures  $\mathbb{P}_D$  and  $\mathbb{B}_{id}$ . Since the subpicture  $\mathbb{B}_{id}$  is equivalent to the empty picture, we can delete it. Moreover, by Definition 2.1, the subpicture  $\mathbb{P}_D$  transforms  $\mathbb{P}'_D$  as shown in Fig. 4(b). In  $\mathbb{P}'_D$ , we can delete the subpicture  $\mathbb{S}_w$  (see Fig. 4(a)), since it is equivalent to the empty picture (by applying the operations on monoid pictures [3,9]). Furthermore, by applying a sequence of Definition 2.1, we obtain the picture  $\mathbb{P}_W^2$  (see Fig. 4(c)) which is equivalent (relative to  $\mathbf{Y}_3$ ) to the empty picture. In fact, all above processes show that the picture  $\mathbb{P}_W$  is equivalent (relative to  $\mathbf{Y}$ ) to the empty picture, as required.  $\square$

The following lemma can be thought as a dual of the above lemma.

**Lemma 2.3.** *If  $W$  does not define any element of  $L$ , then  $\mathbb{P}_W$  is not equivalent to the empty picture (relative to  $\mathbf{Y}$ ) over  $\mathcal{P}_T$ .*

**Proof.** Suppose that  $W$  does not define an element of  $L$  and suppose also that  $\mathbb{P}_W$  can be obtained from the spherical monoid pictures in  $\mathbf{Y}$ . Let  $P_2^{(l)}$  be the free left  $\mathbb{Z}T$ -module with basis  $\{e_s : s \in \mathbf{s}\} \cup \{e_{x^2=x}\} \cup \{e_{yx=xy} : y \in \mathbf{y}\}$ . Now we will determine the image of  $\mathbb{P}_W$  in  $P_2^{(l)}$ . For the sake of simplicity, let us label the relator  $x^2 = x$  by  $C$ .

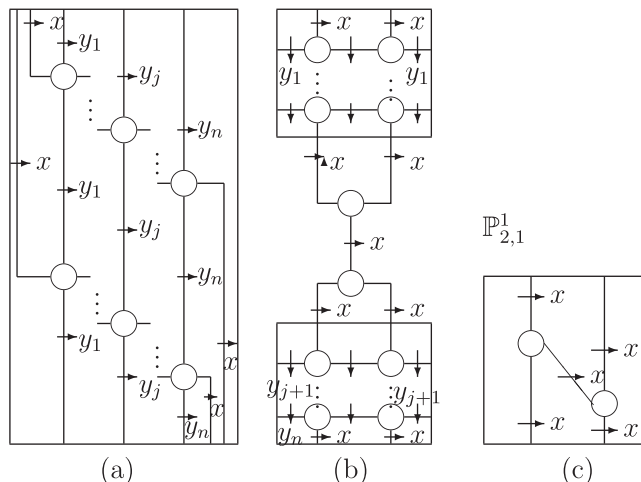

**Fig. 1.** (a) Commutator monoid picture, (b) commutator monoid picture and (c) picture  $\mathbb{P}_{2,1}^1$ .

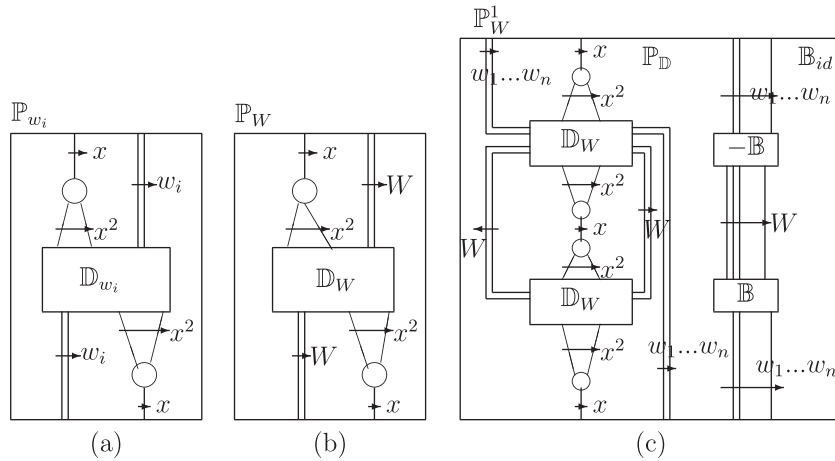

Fig. 2. (a) Monoid picture  $\mathbb{P}_{w_i}$ , (b) monoid picture  $\mathbb{P}_W$  and (c) monoid picture  $\mathbb{P}_W^1$ .

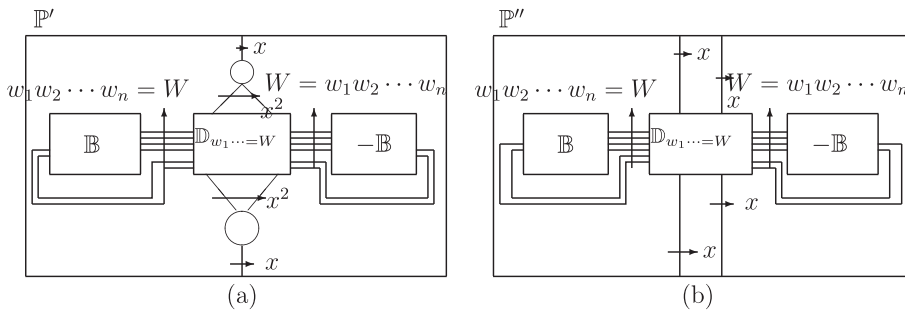

Fig. 3. (a) Monoid picture  $\mathbb{P}'$  and (b) monoid picture  $\mathbb{P}''$ .

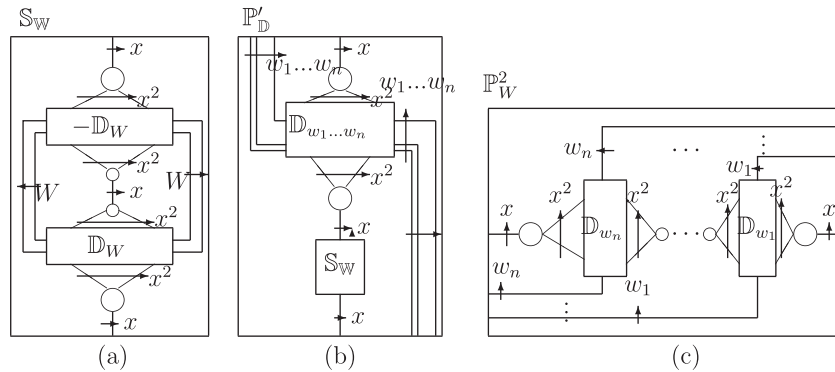

Fig. 4. (a) Subpicture  $\mathbb{S}_W$ , (b) monoid picture  $\mathbb{P}'_D$  and (c) monoid picture  $\mathbb{P}_W^2$ .

Let us take  $P_2^{(l)} = \mathbb{Z}Te_C \oplus P_2'^{(l)}$ , where  $P_2'^{(l)}$  is the free  $\mathbb{Z}T$ -module with the basis excluding  $\{e_C\}$ . (We recall that a *left evaluation* [9], say  $\lambda$ , for a picture  $\mathbb{F}$  is the collection of words over *arcs* from the outer basepoint of  $\mathbb{F}$  to the basepoints of each discs inside of  $\mathbb{F}$ ). Then, as a left evaluation, the image of  $\mathbb{P}_W$  in  $P_2^{(l)}$  is

$$\lambda_W = (\overline{W} - 1)e_C + \lambda'_W$$

for some  $\lambda'_W \in P_2'^{(l)}$ , and the image of  $\mathbb{P}_{w_i}$  ( $\mathbb{P}_{w_i} \in \mathbf{Y}_4$ ) is

$$\lambda_i = (\overline{w_i} - 1)e_C + \lambda'_i$$

for some  $\lambda'_i \in P_2'^{(l)}$ . Also let the image of each  $\mathbb{P}_S$  ( $S \in \mathbf{s}$ ) be  $\lambda_S$  and let, for a picture  $\mathbb{Q}_R$  ( $\mathbb{Q}_R \in \mathbf{Y}_1$ ), the image of  $\mathbb{Q}_R$  be  $\lambda_{\mathbb{Q}_R}$ . We should note that  $\lambda_S$  and  $\lambda_{\mathbb{Q}_R}$  are contained in  $P_2'^{(l)}$ .

By the assumption, since  $\mathbb{P}_W$  can be obtained from the spherical pictures in the set  $\mathbf{Y}$ , we have

$$\lambda_W = \beta_1 \lambda_1 + \beta_2 \lambda_2 + \cdots + \beta_n \lambda_n + \alpha_0 \lambda_C + \sum_{S \in \mathfrak{s}} \alpha_S \lambda_S + \sum_{Q_R \in \mathbf{Y}_1} \alpha_{Q,R} \lambda_{Q,R},$$

where each  $\alpha$ 's and  $\beta$ 's belongs to  $\mathbb{Z}T$ . Now if we equalize the coefficients of  $e_C$ , then we get

$$\overline{W} - 1 = \beta_1(\overline{w}_1 - 1) + \beta_2(\overline{w}_2 - 1) + \cdots + \beta_n(\overline{w}_n - 1) + \alpha_0(\overline{x} - 1).$$

After all, by considering the induced ring homomorphism

$$\mathbb{Z}T \rightarrow \mathbb{Z}M \rightarrow \mathbb{Z}(M/L), \quad \bar{y}_i \mapsto \bar{y}_i \mapsto \bar{y}_i L (y \in \mathbf{y}), \quad \bar{x} \mapsto 1 \mapsto 1L,$$

we obtain  $\overline{W}L - 1L = 0$ . In other words,  $W$  defines an element  $\overline{W}$  of  $L$  which contradicts with our assumption.

Hence the result.  $\square$

### Acknowledgement:

Third and fifth authors are supported by the Commission of Scientific Research Projects (BAP) of Selcuk University. Fourth author is supported by the Commission of Scientific Research Projects of Uludag University, Project No's: 2006/40, 2008/31 and 2008/54.

### References

- [1] W.A. Bogley, S.J. Pride, Calculating generators of  $\pi_2$ , in: Two-dimensional homotopy and combinatorial group theory, London Mathematical Society Lecture Note Series, vol. 197, Cambridge Univ. Press, Cambridge, 1993, pp. 157–188.
- [2] R.V. Book, F. Otto, String-rewriting systems, Texts and Monographs in Computer Science, Springer-Verlag, New York, 1993. pp. viii+189 ISBN: 0-387-97965-4.
- [3] A.S. Çevik, The  $p$ -Cockcroft property of the semi-direct products of monoids, Int. J. Algebra Comput. 13 (1) (2003) 1–16.
- [4] R. Cremanns, F. Otto, Finite derivation type implies the homological finiteness condition  $FP_3$ , J. Symbolic Comput. 18 (2) (1994) 91–112.
- [5] A. Graovac, T. Pianski, On the Wiener index of a graph mathematical chemistry and computation (Dubrovnik, 1990), J. Math. Chem. 8 (1–3) (1991) 53–62.
- [6] A.D. Güngör, A new like quantity based on "Estrada index, J. Inequal. Appl (2010) 11. Article ID 904196.
- [7] I. Gutman, The energy of a graph: old and new results, Algebraic combinatorics and applications (Göβweinstein, 1999), Springer, Berlin, 2001. pp. 196–211.
- [8] P.S. Novikov, Ob algoritmičeskoj nerazrešimosti problemy tošdestva slov v teorii grupp, (Russian) [On the algorithmic unsolvability of the word problem in group theory.], Trudy Mat. Inst. im. Steklov, no. 44, Izdat. Akad. Nauk SSSR, Moscow, 1955, p. 143
- [9] S.J. Pride, Geometric methods in combinatorial semigroup theory, Semigroups, formal languages and groups (York 1993), NATO Adv. Sci. Inst. Ser. C Math. Phys. Sci., vol. 466, Kluwer Academic Publisher, Dordrecht, 1995. pp. 215–232.
- [10] C.C. Squier, Word problems and a homological finiteness condition for monoids, J. Pure Appl. Algebra 49 (1–2) (1987) 201–217.

**Record 1 of 1****Title:** The next step of the word problem over monoids**Author(s):** Karpuz, EG (Karpuz, E. Guzel); Ates, F (Ates, Firat); Cevik, AS (Cevik, A. Sinan); Cangul, IN (Cangul, I. Naci); Maden, AD (Maden (Gungor), A. Dilek)**Source:** APPLIED MATHEMATICS AND COMPUTATION Volume: 218 Issue: 3 Special Issue: SI Pages: 794-798 DOI: 10.1016/j.amc.2011.03.076 Published: OCT 1 2011**Times Cited in Web of Science:** 0**Total Times Cited:** 0**Cited Reference Count:** 10**Abstract:** It is known that a group presentation  $P$  can be regarded as a 2-complex with a single 0-cell. Thus we can consider a 3-complex with a single 0-cell which is known as a 3-presentation. Similarly, we can also consider 3-presentations for monoids. In this paper, by using spherical monoid pictures, we show that there exists a finite 3-monoid-presentation which has unsolvable "generalized identity problem" that can be thought as the next step (or one-dimension higher) of the word problem for monoids. We note that the method used in this paper has chemical and physical applications. (C) 2011 Elsevier Inc. All rights reserved.**Accession Number:** WOS:000294298400030**Language:** English**Document Type:** Article**Author Keywords:** Monoid pictures; Word problem; Presentation; Identity problem**KeyWords Plus:** HOMOLOGICAL FINITENESS CONDITION**Addresses:** [Karpuz, E. Guzel] Karamanoglu Mehmetbey Univ, Kamil Ozdag Sci Fac, Dept Math, TR-70200 Karaman, Turkey

[Ates, Firat] Balikesir Univ, Fac Arts &amp; Sci, Dept Math, TR-10145 Balikesir, Turkey

[Cevik, A. Sinan; Maden (Gungor), A. Dilek] Selcuk Univ, Dept Math, Fac Sci, TR-42075 Konya, Turkey

[Cangul, I. Naci] Uludag Univ, Fac Arts &amp; Sci, Dept Math, TR-16059 Bursa, Turkey

**Reprint Address:** Karpuz, EG (reprint author), Karamanoglu Mehmetbey Univ, Kamil Ozdag Sci Fac, Dept Math, Yunus Emre Campus, TR-70200 Karaman, Turkey.**E-mail Address:** eylem.guzel@kmu.edu.tr; firat@balikesir.edu.tr; sinan.cevik@selcuk.edu.tr; cangul@uludag.edu.tr; agungor@selcuk.edu.tr**Publisher:** ELSEVIER SCIENCE INC**Publisher Address:** 360 PARK AVE SOUTH, NEW YORK, NY 10010-1710 USA**Web of Science Categories:** Mathematics, Applied**Research Areas:** Mathematics**IDS Number:** 812MU**ISSN:** 0096-3003**29-char Source Abbrev.:** APPL MATH COMPUT**ISO Source Abbrev.:** Appl. Math. Comput.**Source Item Page Count:** 5**Funding:**

Funding Agency	Grant Number
Commission of Scientific Research Projects (BAP) of Selcuk University	
	2006/40
Commission of Scientific Research Projects of Uludag University	2008/31
	2008/54

Third and fifth authors are supported by the Commission of Scientific Research Projects (BAP) of Selcuk